

H

HULK EARTH ANCHORS

HULK Earth Anchors

PIPELINE STABILITY AND BUOYANCY CONTROL

- Concrete free anchoring solution.
- Fast, labour saving installation.
- Anchors proof tested during installation.
- Immediate holding capacities.
- Suits all soil conditions.

Percussion driven Hulk Earth Anchors provide innovative and cost effective anchoring solutions for the Civil, Construction, Marine, Mining and Natural Gas industries.

Hulk percussion anchors are contemporary and functional devices that are rapidly deployed and instantly ready for use in most ground conditions. Hulk engineered anchoring systems offer a lightweight, corrosion resistant anchor that is installed from ground level using light weight and readily available equipment.

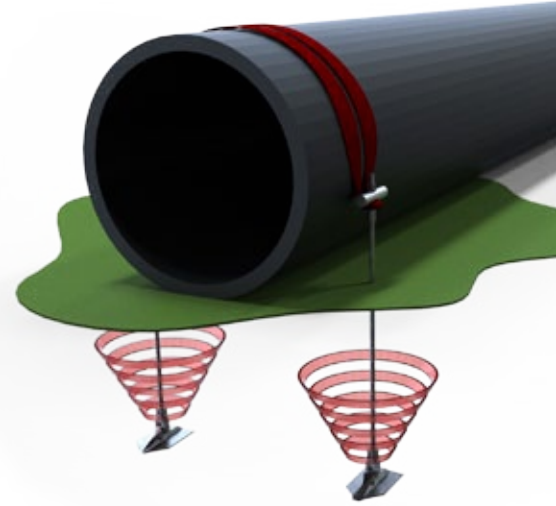

Hulk Earth Anchors can also be used to retrofit existing pipelines both above and below the ground.

Hulk Earth Anchors displace a minimal amount of soil during installation and can be proof tested to an exact specified load.

As a dry system Hulk anchors are environmentally friendly, however they can be grouted where site conditions require it.

A variety of termination and tensioning fixtures are available ranging from saddles to webbing systems and bungy cords.

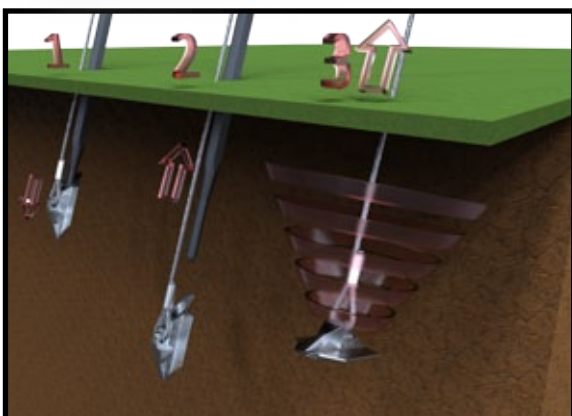

HOW HULK EARTH ANCHORS WORK

- 1) Drive the HULK Earth Anchor into the ground with a reusable HULK Smasher Rod.
- 2) Remove the HULK Smasher Rod.
- 3) Anchor Lock the HULK Earth Anchor while simultaneously Proof Testing.

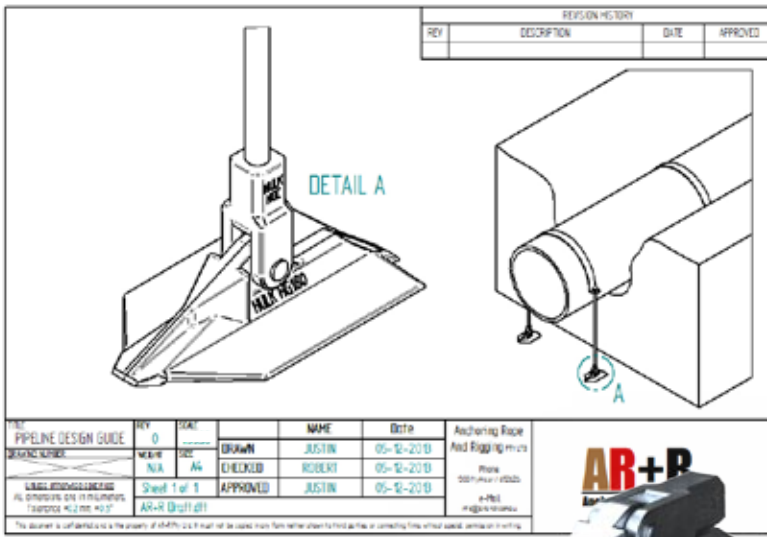

Our design team is available to offer technical support and customisable solutions to meet your project requirements.

The H and HG range of HULK Earth Anchors cover a wide range from light weight to heavy weight solutions. Load capacities range from 10 kN up to 200 kN.



For further advice and technical information visit www.hulkearthanchors.com or call 1300 692 626

HULK EARTH ANCHORS HOLDING CAPACITY IN kN

Soil Description	Blow Count (N)	HULK H50	HULK H80	HULK H110	HULK HG100	HULK HG180	HULK HG320
Very dense/cemented sands; Coarse gravel and cobbles	60+	45 (1,3)	45 (1,3)	45 (1,3)	140-280 (1,3)	N/A (5)	N/A (5)
Dense fine compacted sands, very hard silts or clays	45-60	27 -45 (2,3,4)	45 (2,3)	45 (2,3)	105-140 (2,4)	170-280 (1,3,4)	201-280 (1,3)
Dense Clays, Sands and gravels, hard silts and clays	35-50	18 - 27 (4)	24 - 36 (4)	45 (2,3)	75-100 (2,4)	113-170 (2,4)	160-201 (2,3,4)
Medium dense sandy gravel, stiff to hard silts and clays	24-40	13 - 18 (4)	18 - 22 (4)	23 - 30 (4)	60-90 (4)	85-95 (2,4)	121-170 (2,4)
Medium Dense Coarse sand and sandy gravel, Stiff to Very stiff silts and Clays	14-25	9 - 13 (4)	14 - 18 (4)	18- 23 (4)	45-60 (4)	40-95 (4)	90-121 (4)
Loose to Medium Dense Fine to Coarse Sand: Firm to Stiff Clays and Silts	7-14	7 - 11 (4)	9 - 16 (4)	13 - 20 (4)	35-50 (4)	47-71 (4)	70-90 (4)
Loose Fine Sand, Alluvium, Soft Clays, Fine saturated Silty Sand	4-8	4 - 7 (4,6)	6 - 10 (4,6)	8 - 13 (4,6)	25-40 (4,6)	38-56 (4,6)	45-70 (4,6)
				"H" Range anchors based on an installation depth of 1.2m cabled with an 8mm wire rope tendon.		"HG" Range anchors based on an installation depth of 2.1m, installed with a 22mmØ CTB anchor rod.	

- 1) Drilled pilot hole required for efficient installation
- 2) Ease of installation may be improved by drilling a pilot hole
- 3) Holding capacity limited by ultimate strength of anchors
- 4) Holding capacity limited by soil structure
- 5) Not recommended in these soils
- 6) Wide variation in soil properties reduces prediction accuracy. Pre construction field test is recommended.



www.hulkearthanchors.com
1300 MyAnchor (692626)

Distributed By:



CITISCAPE

16A Calula Drive
Mount Gambier SA
5291 Australia

PO Box 9575
Mount Gambier SA
5291 Australia

T. 1300 512 484
E. sales@citiscap.com.au
www.citiscap.com.au